

Gateway

4956

How to connect to APP?

1. Click "+" on the right top corner , see picture 1

2. Find "Gateway control-Wireless Gateway(BLE)", see picture 2

3. Press resetting key of the GATEWAY , and the indicator light will be flashing, see picture 3.

4. In the meantime the App will search the device nearby, see picture 4

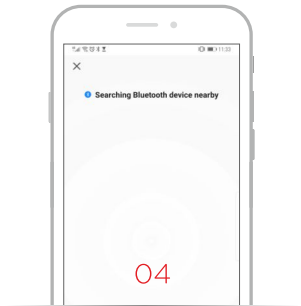
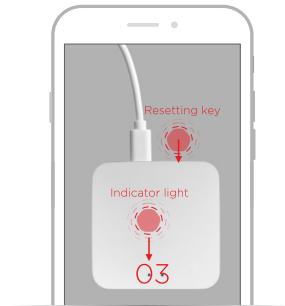
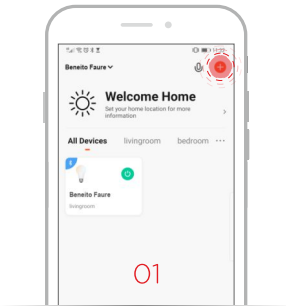

5. Picture 5 & 6 showing found devices and connecting

6. And then show up the WIFI connection, use your wifi and password, see picture 7

7. GATEWAY device connecting complete and successful, click "✓" confirm. see picture 8

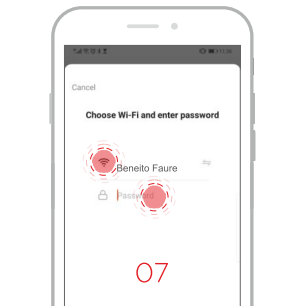

Product Information

8. Click "Done" on the right top corner to complete the added. see picture 9

9. You have successfully added the GATEWAY to the APP. see picture 10.

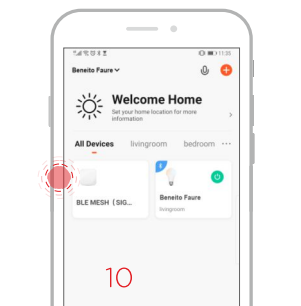
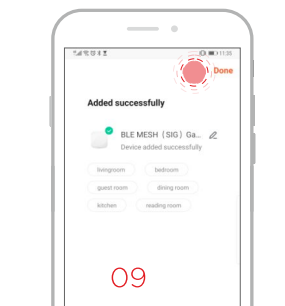
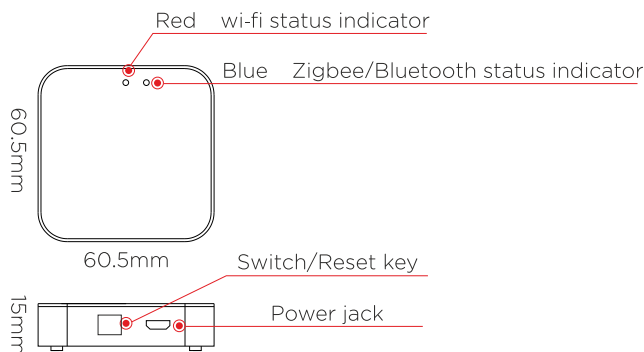

1. Connect to the power supplier.
2. Make sure the indicator light (red light) flashing. If it's show diferente state, long press reset key till the red light flashing.
3. Make sure your mobile phone is connected to a with 2.4GHz router. The mobile and the Gateway are connected the same LAN.